

# **Solar Oven Project**

**Engineering and Technology II**

**Mr. Clark Period 1**

**January 31<sup>st</sup>, 2018**

**Team Name: Avengers Infinity War**

**By: Kim Do**

**Team Members:**

**Skyler Mitchell**

**Ethan Hufault**

## Abstract

Our experiment with the solar oven was highly successful. Despite our inaccurate cardboard cuts and minor errors with the smoothness of our reflectors, our design was able to reach a maximum degree of 116.7 degrees Celsius; almost exactly what our prediction said it would be which was 117.3 degrees Celsius. After constructing our solar oven, we were satisfied with our initial design due to it being well insulated and sufficiently made. Our oven was about the same size compared to other groups but ours had the sloppiest measurements and surface materials. But our solar oven was large, meaning it isn't efficient in terms of material cost. However, even not being able to successfully obtain our desired temperature, we were able to have a maximum temperature of 116.7 degrees. Our experiment was done around noon during January, where the sun was fairly high. We had some changes in the temperature due to the shifting the angle of the solar oven to align the "moving" sun and avoiding the shadows that occurred. Overall, our solar oven was able to keep constant once it reached its maximum temperature, demonstrating that we could cook food in it as well.

## Table of Contents

Introduction.....	4
Design Theory and Analytical Model.....	5
Design Requirements .....	8
Design Description.....	9
Design Justification.....	11
Test Procedure .....	12
Test Results.....	13
Team Dynamics .....	15
Design Critique and Summary.....	16
References.....	19
Appendices.....	20
Solar Oven Performance Index Details.....	23

## Introduction

The motivation for this project was how simple the solar oven itself can be. The main materials we used for the solar oven were cardboard, tape, newspapers, and reflectors; all are which relatively inexpensive items that could even be found at home. Even if we didn't have these materials, they are cheap and easy to acquire. In addition, these crafted solar ovens can be used almost anywhere as long as the sun is out and the sun's rays. They become an appealing design because of its effectiveness and inexpensive. Moreover, the solar oven conserves energy in that instead of using electricity or any other fueling sources (ex. Coal, fire), we learn how to conserve energy and building this project helps us experience the engineering field. We had hope to learn that as working as a group, we would be able to make the most successful oven as possible. As a team, we combined our ideas and worked together to resolve problems that we encountered along the way. In terms of the experiment itself, we had hope to analyze which variables affected the solar oven and that once we discovered the right variables to change, we could end up with the best prediction model with the high temperature possible. The concepts we were expected to explore is learning how to test the oven itself and being able to change a few variables in order to keep increasing the temperature to its maximum.

## Design Theory and Analytical Model

The basic design theory began with this overall equation of the solar oven is shown here:

$$T_{io} = T_{ambient} + \frac{I_o \cdot A_w \cdot \tau^n \cdot a \cdot \sin(\theta_s + \beta)}{(U_{sb} \cdot A_{sb} + U_w \cdot A_w)}$$

The equation overall is complicated due to the derivations that were involved in order to come out with this result. In order to break down it down, below are the defined variables and units for the equations.

Variable	Terminology and Units
$I_o$	solar oven density (W/m <sup>2</sup> )
$\tau$	transmissivity for single layer of mylar
$a$	absorptivity of oven chamber and contents
$r$	reflectivity of Al foil
$T_{ambient}$	ambient temperature (°C)
$L$	length of oven window (cm)
$h$	height of oven chamber (cm)
$n$	# of layers
$M$	length of reflectors (cm)
$A_w$	area of the window (cm <sup>2</sup> )
$A_{sb}$	area of the sides and bottom (cm <sup>2</sup> )
$V_{chamber}$	volume of the oven chamber (cm <sup>3</sup> )
$U_{sb}$	heat transfer coefficient for the sides and bottom of chamber
$U_w$	thermal con of side and bottom
$M/L$	ratio of reflector length to oven window length
$\alpha$	angle of the window
$\theta_s$	angle of the sun (°)
$\beta$	angle of the box to the ground (°)
$T_{io}$	Temperature in the oven (°C)
$G$	Gain

The equation itself is explanatory once it becomes understandable. The specifications dealt with variables that were related to the materials we were using, such as the dimensions of the box (height, width, and weight), oven itself (cardboard), insulation (newspapers), and other factors such as reflectors and window type, shape, and size. To find the area of the window, sides, and bottom of the chamber, use the simple area formulas because it is mainly in shapes of squares or rectangles. Finding the volume of the chamber is the same by multiplying the length of the window twice with the height of the oven chamber. Here are some additional equations in order to be used for the main equations:

$$U_{sb} = \frac{1}{\frac{x_1}{k_1} + \frac{x_2}{k_2} + \frac{x_3}{k_3}}$$

$$G = 1 + r \cdot \left(\frac{M}{L}\right) \cdot \sin \alpha$$

The  $U_{sb}$  is determined by the material you pick for the insulation and is basically the overall heat transfer coefficient for the sides and bottom of the interior oven chamber. The  $k_1$ ,  $k_2$ , and  $k_3$  are all thermal conductivity while the  $x_1$ ,  $x_2$ , and  $x_3$  are determined by the thickness of the cardboard what we use. The equation derived for  $G$  is based on the assumption that an oven tiled at angle  $\beta$  such that the sun's rays strike the window at normal incidence. One of the original equations of  $G$  is  $P_{\text{absorbed with a reflector}} = G * P_{\text{absorbed without a reflector}}$  and the gain term  $G$  is a number that depends solely on the geometry (size and angular position) of the reflectors. After substituting  $P_{\text{absorbed}} = I_o A_w * \tau * a * \sin(\theta_s + \beta)$ , we will eventually end up with the Gain equation as shown above.

In terms of heat lost from the oven chamber, there are three types of them: conduction, convection, and radiation. To prevent these heat losses, we considered many ideas. For example,

to prevent convective losses, we used black duct tape in order to cover up any holes that could be possible for air molecules to come in contact with the hot oven chamber; even the tiny “closed-air spaces” in order to limit their motion inside the oven box. In addition, to prevent conductive losses, insulation was also considered when putting black paint around the exterior box in order to absorb heat from the outside because the darker the box is, the easier it helped keeping the heat closer to the insulation ,warming up the interior smaller box. However, it was difficult preventing radiation loss considering that since it occurs from the hot window itself, we couldn’t do much about it and also we couldn’t touch it during the process of our experiment. One Mylar window was used as well in order to direct the heat to the designated area. The predicted temperatures we had were 117.32, 116.56, 112.81, and 109.12 degrees Celsius. We chose the highest predicted temperature we could come up with and it was 117.32 °C. Below is the predicted graph of combination one, which was our highest temperature.

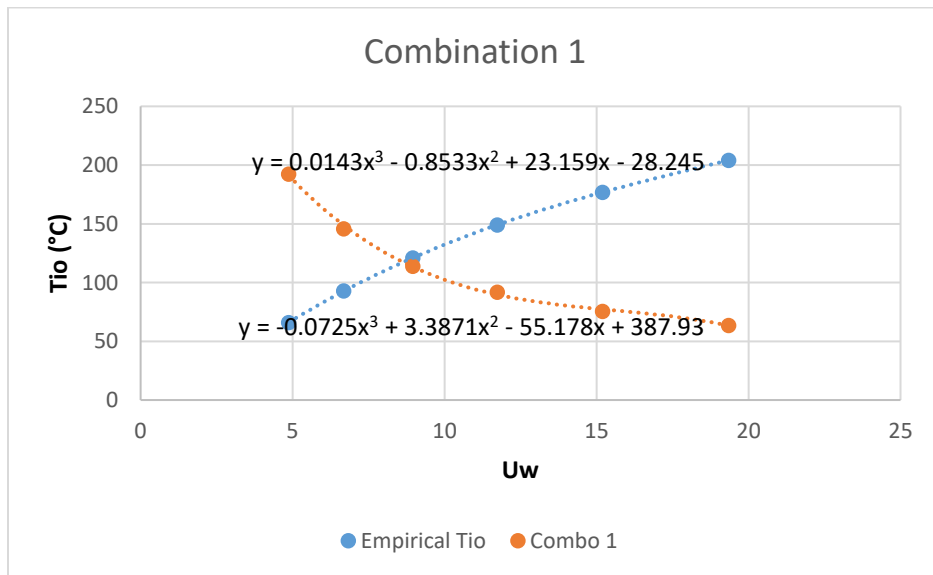

## Design Requirements

There were many requirements and guidelines that were given to us to lead us to our design experiments. First of all, the design of the solar oven needed to be made out of cardboard and the shape of a box for the window opening had to be a square for consistency and to make calculations less complicated. The oven cooking chamber volume should be  $1000 \text{ cm}^3$  and the length (L) and height (h) need to be at a minimum of 5cm each. Aside from the sides of the box, the top of the outer chamber had to be flat, not sloped or steeped. Second of all, the oven had to somehow access a digital thermometer that will stick through the oven wall (not oven window) in order to measure the temperature inside the cooking chamber. The shape of the reflectors had to be either rectangular or trapezoidal and our group chose trapezoidal in order to have the sun to start out with a bigger “starting point” and end up having a “focal point”. However, focusing lenses or parabolic designs aren’t permitted; only mylar sheets. Furthermore, the maximum M/L ratio had to be 3. The oven is expected to have a minimum oven temperature of  $100 \text{ }^\circ\text{C}$ . One of the biggest constraints that wasn’t mentioned necessarily on the solar oven rules was that we had to use the minimum amount of resources and most effective way as possible. For example, we shouldn’t use a whole roll of duct tape freely just because it’s there; we had to consider the limit amount of materials we had in order to have a high performance index.



## Design Description

Our solar oven design was a common and simple one. After inputting four combinations, our highest predicted temperature is 117.3 °C and therefore, we decided to go with that design parameters. Our exterior cardboard design was sprayed painted with black in order to have insulation. In addition, the dimension was 25x25 cm. Our interior box (the oven cooking chamber) has the walls duct taped in order to again, insulate the heat. The dimension for that was 10x10 cm. Between the small box and the big box, we crumbled up wadded newspapers in order to reduce heat loss. As you can see in the picture below, there are lots of black duct tape that is messily wrapped around the box in order to seal all the possible holes and openings for the heat to be kept inside. Then, to make the reflectors, we cut four cardboard trapezoidal shapes and wrapped the reflector sheets (and make it as smooth as possible) and taped the shorter end of the trapezoid on top of the cooking chamber (small box). We chose trapezoidal shapes instead of rectangular ones in order for the sunlight to concentrate its heat into the chamber and target the one myler sheet.



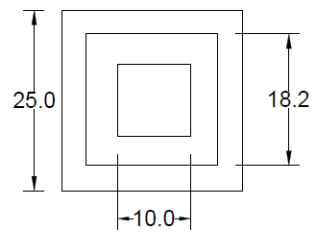

Units: Cm

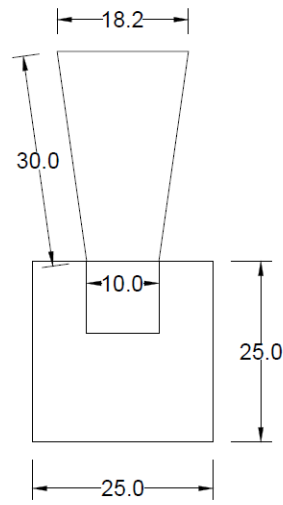
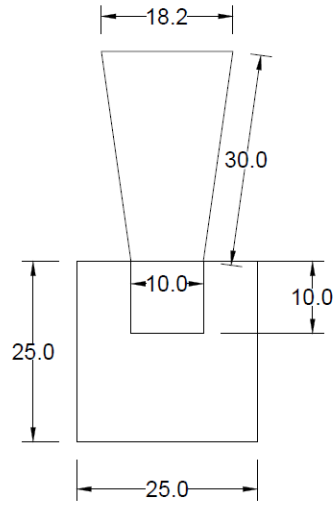

2D AutoCad Technical Drawing of Solar Oven Design

## Design Justification

We selected the designs based off of the University of Arizona solar oven documents and did some research regarding past successful solar ovens. At first, we considered to make our solar oven box very small in order to have an efficient cost of materials and that there was a possibility of having a small box could confine the heat to a smaller location. However, due to having the maximum volume design, we decided to make it bigger, an improvement that was quite successful. Our insulation materials were mainly black duct tape, black spray paint, and wadded newspapers in order to have the most effective insulation. The outer box was spray painted entirely black in order to not only have an effective insulation compared to construction paper, but to also save resources because we learned that groups in the past used black construction paper, which wasn't effective and cost more money. To conclude, our solar oven design was based on popular designs and also taking in tips and advice that past successful oven designs stated.

## Test Procedure

During the testing experiment, we tested it outside our school on the sidewalk where the most of the sun was because there were too many shades and shadows around the school campus. The ambient temperature was 20.2 degrees and since it was tested around noon, the sun was almost at its peak point during the day, giving us some efficiency with the solar oven. The oven was set up at an angle using small wood blocks and our oven was directly aligned with the sun to maximize the amount of light and heat that our box would be exposed to. One member kept making sure the box was aligned with the sun where there were no shadows inside the chamber. We had the solar oven out for about 45 minutes and we constantly shifted the box little by little in order to have the sun align with it correctly. Moreover, we stabbed the thermometer through the big box and little box (not through the window, but through the wall) in order to record the temperature for our data. Due to solar oven being light enough to carry, it was effective to have it being moved around.

We did the same procedure when we did the experiment a second time on January 30<sup>th</sup>, 2018 in order to gather data for a temperature versus time. However, in this experiment only occurred for a solid ten minutes due to the short amount of time we had.

## Test Results

Our test results were highly successful. We have obtained a maximum temperature of 116.7 degrees Celsius which was only 0.1 away from our predicted temperature of 116.6 degrees Celsius. During the test, we constantly shifted the box little by little in order for it to follow the sunlight and prevent shadows from touching the window. We also added little bit of ductape in order to cover the tiny hole around the thermometer after it was inserted. Construction imperfections or real-world issues that were involved was the mainly the wind. The wind wasn't as strong, but strong enough to slightly move our solar oven, causing errors to be involved considering there were specific angles we wanted the solar oven to be at. Something to note is that we took this experiment during the winter time and therefore there is a possibility of having a much higher temperature if we took the experiment during the summer. The cold weather could have affected the increase of temperature such that it could have increased much faster if it was taken during the summer heat. Furthermore, a couple of students accidentally passed by and blocked the sunlight from the reflectors for about 1 second, causing the temperature to suddenly drop down a few degrees. These issues could be minimized in the future by having the experiment in a place where there aren't many students. We could have also created a sign warning people not to pass by while the experiment is in progress. To fix the wind issue, we could have slowly duct taped down the box to the ground but not too much because we needed to shift the box multiple times as time passes. The behavior of  $I_0$  increased from 1000 to 1015.8  $W/m^2$ , which also in turn increased our predicted temperature.

For our second experiment, we weren't able to achieve our highest temperature due to a ten minute limit, but during 8:20 am till 8:30 am, the sun was starting to rise and the ambient temperature was 14.4 degrees outside. There was also a little more wind, but mainly similar

weather conditions during the first experiment. Below are our test results for out temperature versus time.

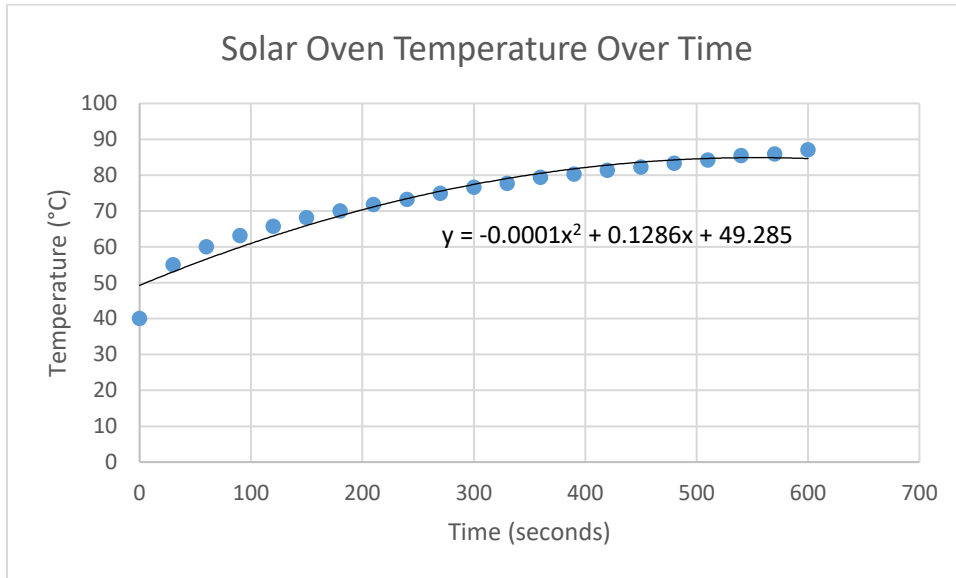

## Team Dynamics

Kim Do: Designed the whole entire excel spreadsheet. Came up with the design dimensions and explained the whole concept of the solar oven equations and design to group. Helped cut some of the cardboard out in order to have accurate measurements. Duct taped some of the cardboard together. Brought in the newspapers and putting the reflector sheets on. Sent results and excel sheet to group by email. Constantly checked the temperature every 3 minutes to see if it has progressed. Created technical drawing on AutoCad.

Skyler Mitchell: Mainly constructed the design and aided a little of how it should look like. Made some cardboard cuts and measurements with measuring tape. Brought in extra newspapers. Took pictures of the solar oven. Found some of the flaws and fixed them (for ex. taping the smallest gaps), Found most of the material. Pitched in ideas. Scheduled and set up the solar oven for the test. Chose the angle and spot to put the solar oven. (Scale Rating: 9)

Ethan Hufault: Supported members of the team. Contributed ideas to the project. Offered to help multiple times. Gathered up most of the materials when we needed it. Asked many questions that helped our group develop better ideas and also to make sure we were doing things correctly. (Scale Rating: 7)

## Design Critique and Summary

Overall, the project was quite successful in its experiment, considering we almost reached our desired temperature. However, our design wasn't perfect and therefore we would have done things differently with our designs, specifically with spending more time on increasing the efficiency of the box dimensions, amount of tape and paint, and angle of the box. First of all, we would have made our cuts more precise because some of our cardboard cuts weren't obviously straight enough, which could possibly cause errors in our measurements. In terms of the dimensions, the requirement was that the dimensions of the box had to be 1000 cm<sup>3</sup> in volume and therefore didn't allow us much time to maximize the efficiency of the amount of heat that entered the oven chamber. If we were given a smaller dimension, it would have possibly made the performance index more efficient due to a decrease in cost of fewer materials. Speaking of materials, our group used up an enormous amount of duct tape more than required considering which therefore increased the our price index and in turn decrease our efficiency of our performance index. However, the increase use in tape allowed for a higher temperature inside the heating chamber because it sealed off any possible areas where heat might have been released. Second of all, we would have made our reflector sheets much smoother in order to have a better sunlight focal point toward our oven chamber. There were minor scratches and "wavy" parts in the reflectors that caused errors in our oven. Third of all, we could have had more insulation in terms of covering every inch of our cardboard with black spray paint (there were a few spots where there was some missing black paint) and also adding more newspapers in order to again, create better insulation. Fourth, the angle of the box when it was positioned out in the sun wasn't perfect such that there was a chance of it being off by a few degrees which can have a major effect on our temperature. Finally, we would have tried better ways in terms of changing the



variables because there is a high possibility that the temperature would have been higher than 116 degrees Celsius. Some recommendations for future teams designing the solar oven would be to go through the list of materials and deciding the most efficient cost and quality in order to help increase the performance index. In addition, they should list the features and variables that was most effective before diving right to build it. In terms of the actual construction of the box, there should be no rush into making a very simple mechanism and after having the desired measurements, there would be careful and precise cuts in order to have the best and working design, especially with making the reflectors as smooth as possible. In terms of the material being used to construct the solar oven, there should be a minimal use of duct tape in order to save efficiency and the effective use of, for example, black spray paint in order to maximize insulation. Newspapers can be used as much as possible considering that it's free. As a final point, during the experiment, in order to have a better angle and exact measurement, there should be a use of a protractor in order to increase precision. Another advice is to do the test during a time where there is minimum wind, shadows, and maximum sunlight. As for the team dynamics, some changes we would have made is mainly time. Our solar oven would have been better constructed nicely if we weren't deciding to put it off near the deadline. However, due to time approaching toward the deadline, we rushed through our project, causing ideal errors that went along the way. We would have also spent more time exploring the excel sheet for more possible high temperatures. Speaking about teamwork though, there were some people who did more work than others so in the future, balancing the work out would have been more fair. Furthermore, the process would have gone more smoothly if we were more organized and communicative. An idea could be having a team leader that could assign specific roles and

assignments for each member of the group and therefore increasing the better efficiency of our time, especially when everyone has a focused job and later combining ideas.

## References

1. *Solar Oven Project* from The University of Arizona College of Engineering (Document)
2. *Solar Oven Excel Sheet Guidelines and Prediction Model* from The University of Arizona College of Engineering (Document)
3. Solar Oven Facts. (n.d.). Retrieved January 20, 2018, from <https://sciencing.com/solar-oven-5365247.html>
4. Writing Guidelines for Engineering and Science Students. (n.d.). Retrieved January 25, 2018, from <http://www.writing.engr.psu.edu/workbooks/design.html>

Appendices

Oven Design Spreadsheet (Excel Prediction Model)

$T_{io} = T_{ambient} + (I_o * A_w * \tau^n * a * G) / (U_{sb} * A_{sb} + U_w * A_w)$				
	Comb.1	Comb. 2	Comb. 3	Comb. 4
<b>Fixed Input Parameters</b>				
$I_o$ (solar oven density) ( $W/m^2$ )	1015.8	1000	1000	1000
$\tau$ (transmissivity for single layer of mylar)	0.92	0.92	0.92	0.92
$a$ (absorptivity of oven chamber and contents)	0.9	0.9	0.9	0.9
$r$ (reflectivity of Al foil)	0.75	0.75	0.75	0.7
<b>Variable Input Parameters</b>				
$T_{ambient}$ (ambient temperature) ( $^{\circ}C$ )	20.2	20.2	20.2	20.2
$L$ (length of oven window) (cm)	10	10	10	10
$h$ (height of oven chamber) (cm)	10	10	10	10
$n$ (# of layers)	1	1	2	3
$M$ (length of reflectors) (cm)	30	20	10	30
$A_w$ (area of the window) ( $cm^2$ )	100	100	100	100
$A_{sb}$ (area of the sides and bottom) ( $cm^2$ )	500	500	500	500
$V_{chamber}$ (volume of the oven chamber) ( $cm^3$ )	1000	1000	1000	1000
$U_{sb}$ (heat transfer coefficient for the sides and bottom of chamber)	0.001361	0.001361	0.001361	0.001361
$M/L$ (ratio of reflector length to oven window length)	3	2	1	3
$\alpha$ (angle of the window)	16.31	21.47	30	16.31
Gain	1	1	1	1
<b>Wall element</b>				
Inner cardboard wall	$x_1$	4	$k_1$	0.064
Insulation	$x_2$	75	$k_2$	0.123
Outer cardboard wall	$x_3$	4	$k_3$	0.064
<b>Predicted <math>T_{io}</math> (<math>^{\circ}C</math>)</b>	<b>117.324</b>	<b>116.5601</b>	<b>112.813</b>	<b>109.122</b>
Resulted Temperature: 116.7 $^{\circ}C$				

$U_{w(\text{single})}$	$U_{w(\text{double})}$	$T_{io}$				
		Empirical $T_{io}$	Combo 1	Combo 2	Combo 3	Combo 4
10.1	4.88	66	192.3129457	189.6358591	176.0809904	163.6105112
13.9	6.69	93	145.7945787	143.8410501	133.9497661	124.8497848
18.66	8.96	121	113.9995643	112.5405831	105.1533364	98.3570695
24.34	11.74	149	91.80095034	90.68725176	85.04827162	79.86040989
31.6	15.2	177	75.50960653	74.64930747	70.29336288	66.28589385
40.11	19.35	204	63.65150974	62.9756544	59.55360204	56.40531388

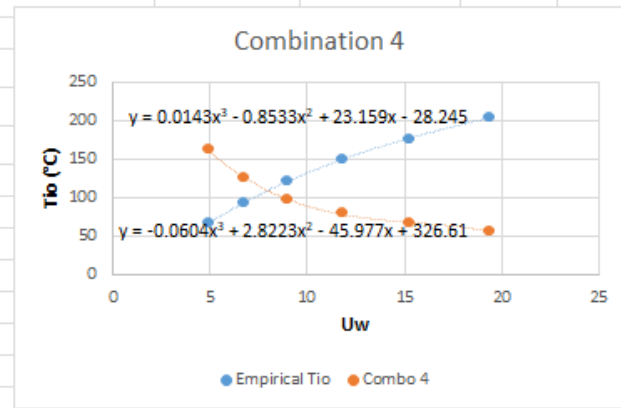
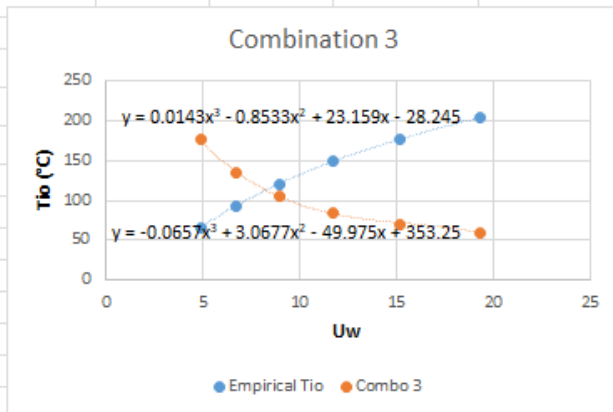
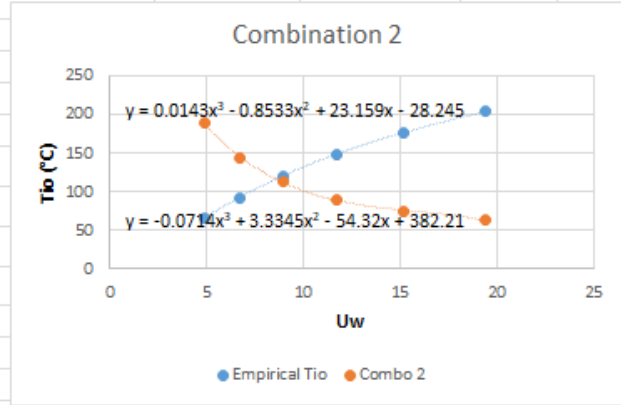
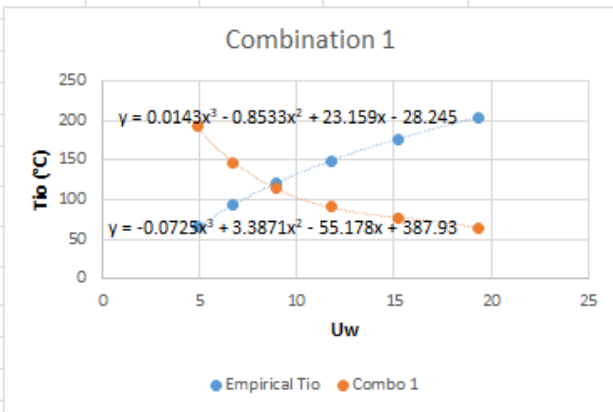

# Brainstorm and Notes

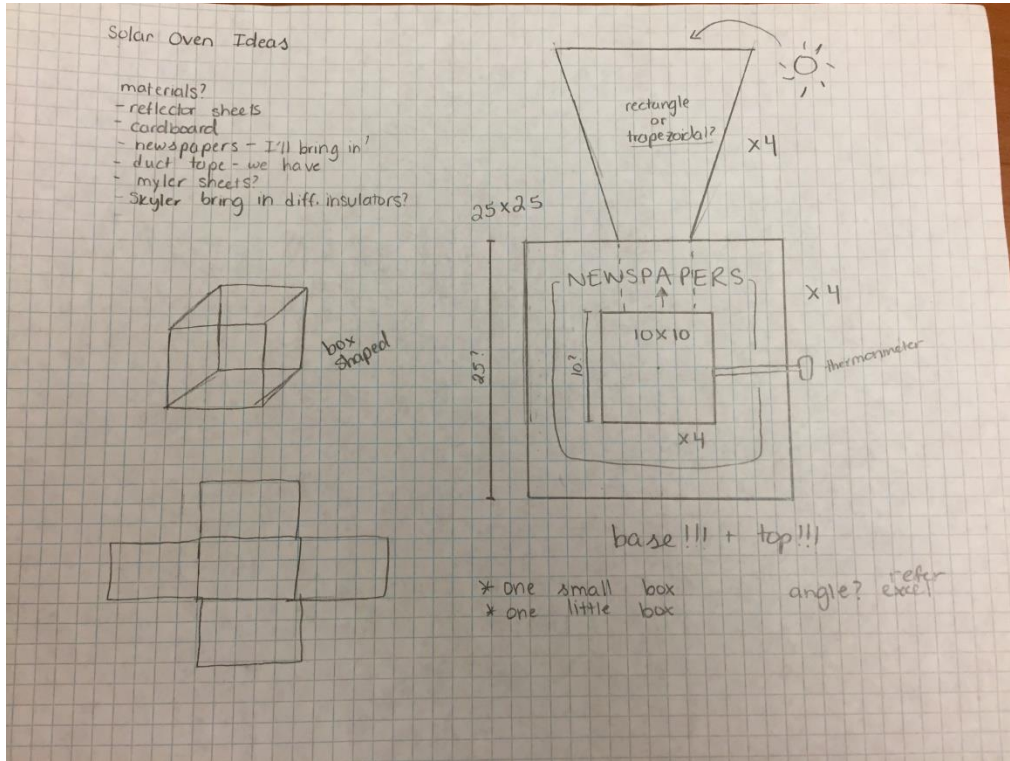

## Solar Oven Performance Index Details

Team Name: Avengers Infinity Wars

Solar Oven cost breakdown:

### 1. Material Cost:

Specific Material	Amount Used	Cost Basis	Cost for Amount Used
Black Duct Tape	10 yds	\$6.67/1.88 in. x 60 yds (per roll)	\$1.10
Black Spray Paint	0.50 oz	\$3.48/12 oz (per can)	\$0.15
Mylar Sheets	1	\$0.25 each	0.25
Cardboard	6000 cm <sup>2</sup>	\$1.75/m <sup>2</sup>	\$1.00
Reflector Sheets	4000 cm <sup>2</sup>	\$0.55/m <sup>2</sup>	\$0.20
Newspapers	Many	Free	\$0.00
<b>TOTAL MATERIAL COST:</b>			\$2.70

### 2. Transportation Cost:

a. Weight of Oven: lb (1.932) X \$.20/lb = \$0.38

3. **Labor Cost:** fixed at \$5.00 per team

4. **Total Oven Cost:** (Material Cost + Transportation Cost + Labor Cost) =

$$(\$2.70 + \$5.00 + \$0.38) = \$8.08$$

5. **Performance Index:**  $T_{\text{ambient}} = (20.2^{\circ}\text{C})$   $T_{\text{actual}} = (116.7^{\circ}\text{C})$

a. **Cost-Based PI** =  $(T_{\text{actual}} - T_{\text{ambient}}) / (\text{Cost}) = (116.7^{\circ}\text{C} - 20.2^{\circ}\text{C}) / (\$8.08) = \mathbf{11.94}$

b. **STOD PI** =  $(T_{\text{actual}}) / ((T_{\text{actual}} - T_{\text{predicted}}) + 1) = (116.7^{\circ}\text{C}) / ((116.7^{\circ}\text{C} - 117.32^{\circ}\text{C}) + 1) =$

$$\mathbf{72.04}$$